

SERIES3

Assembly Instruction Manual

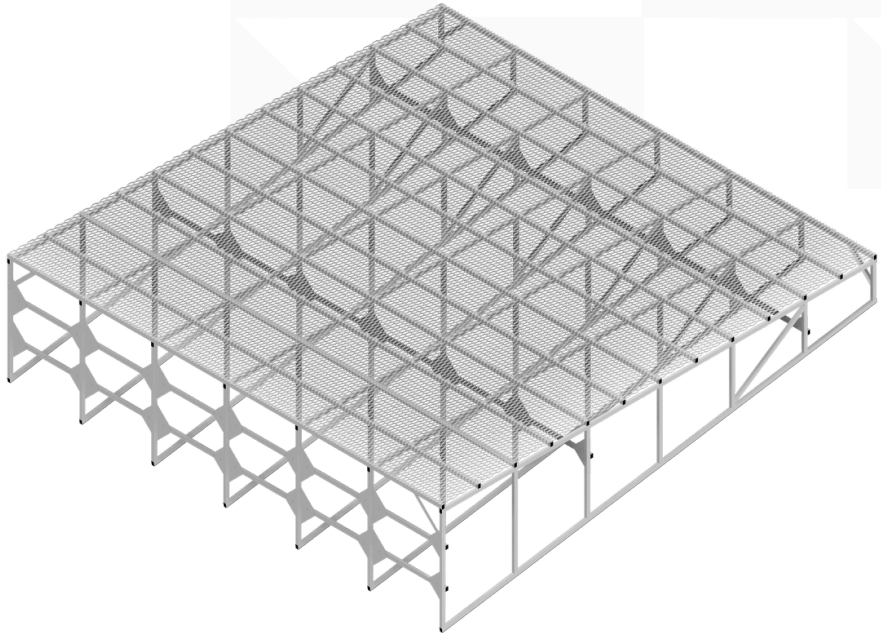

Configured**Platforms**[®]



Prefabricated plant enclosures & platform systems

 **value**engineering[®]

+44 (0)113 276 0450

TechnicalSupport@configuredplatforms.co.uk

www.configuredplatforms.com

Configured **Platforms**[®]

 **value** engineering[®]

SERIES **3**

Screen System for fixing to Parapets

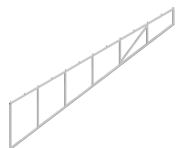

S3 **Frame**



Cross **Support**

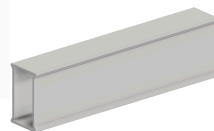

RHS **Splice**



20mm **Tek Screws**



Truss **Brace**



Square **Brace**



Half **Brace**



Quarter **Brace**

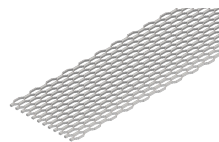

Mesh **Sheet**

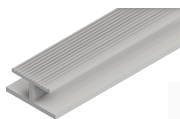

Mesh **Joiner**



35mm **Tek Screw**
+ Hold Down **Disc**



Certification **Plate**

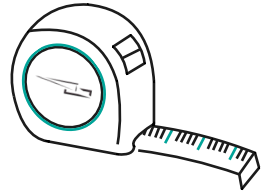
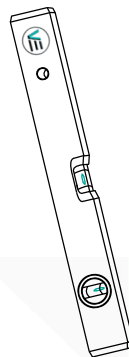
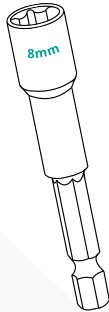
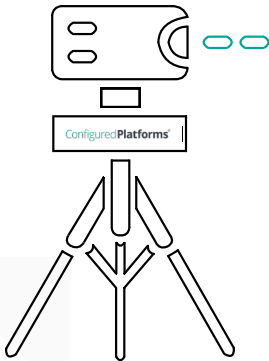
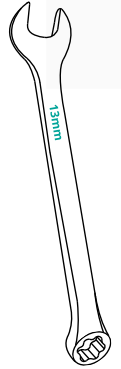
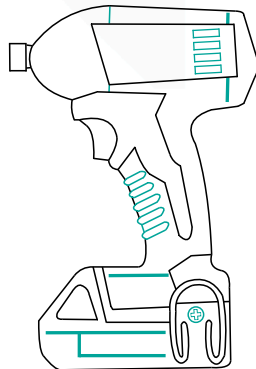
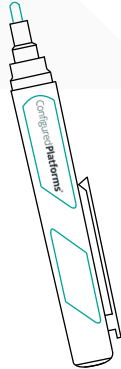

1

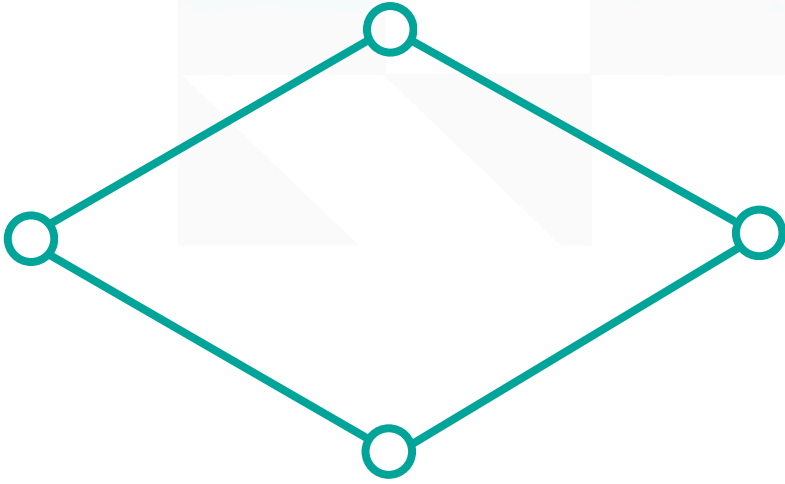

1. Mark out the outline of the platform size in the location where you will place the platform.

2

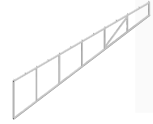
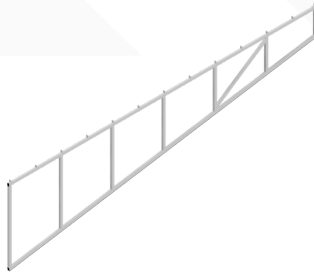
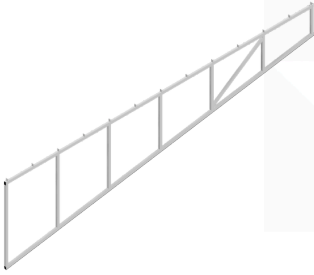

S3 Frame

2. Place a **Frame** to suit the layout at each end of the platform.
Note orientation of the frame.

3

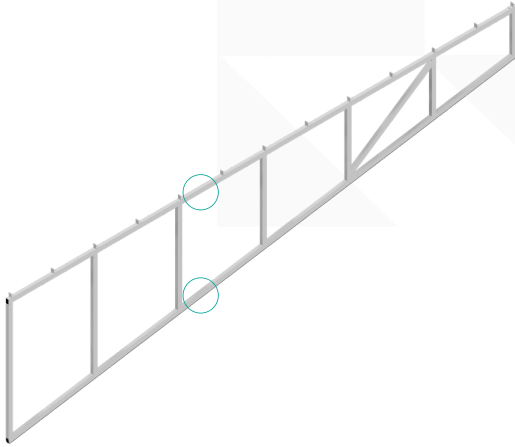

RHS Splice



20mm Tek Screws

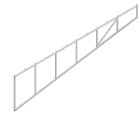

S3 Frame

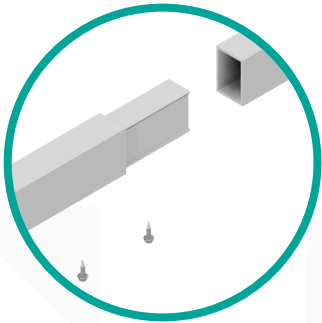

3. If the **Frame's** are supplied in multiple lengths they require connecting using **RHS Splice** and **20mm Tek Screws**.

4

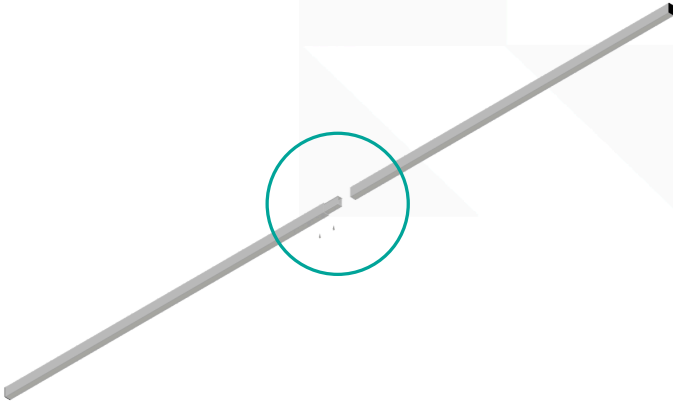

RHS Splice



20mm Tek Screws

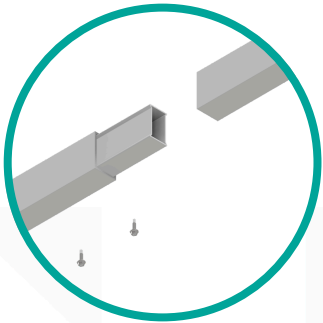

4. If the **Cross Supports** are in multiple lengths, join using **20mm Tek Screws** and the **RHS Splice**

5

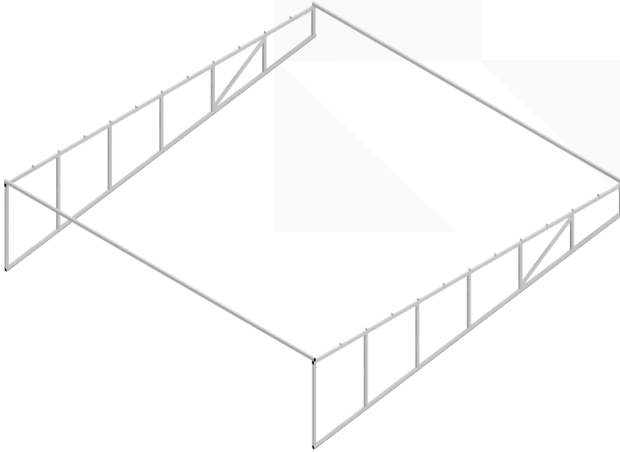

Cross **Support**



20mm **Tek Screws**

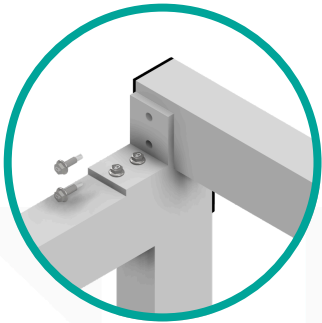

5. Fix a **Cross Support** between the **Frames** on the **small** end of the platform and fix to the Bearer Brackets on the **Frames** using **20mm Tek Screws**. Repeat with the **large** end.

6

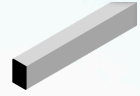
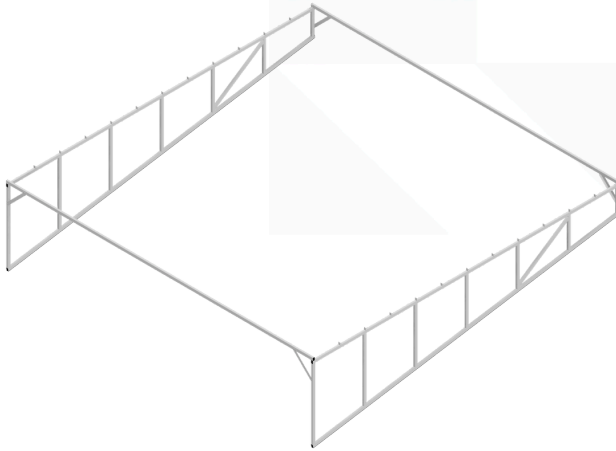

Cross **Support**



Truss **Brace**



20mm **Tek Screw**

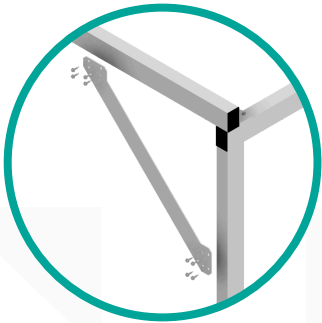

6. Vertically plumb the two **Frames**. Fix a **Truss Brace** between the **Frame** and **Cross Support** at all corners with **20mm Tek Screws**

7

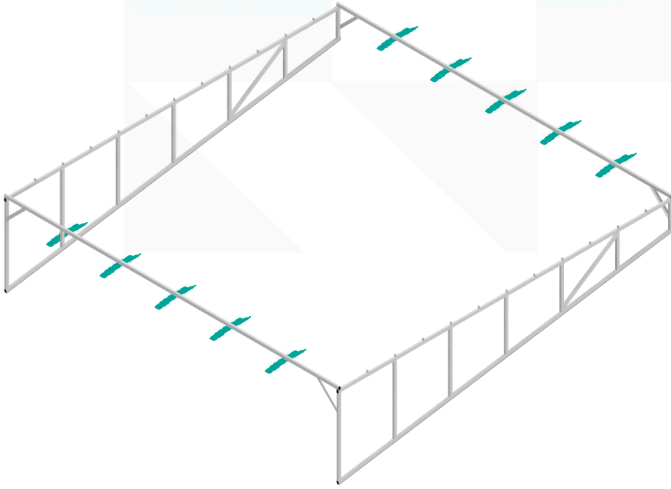

7. Mark the positions for the remaining **Frames**. If positions are not noted on drawing, the **Frames** are equally spaced. (Number of spaces divided by length of platform). Spacing should not be greater than 1200mm unless specified.

8

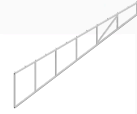
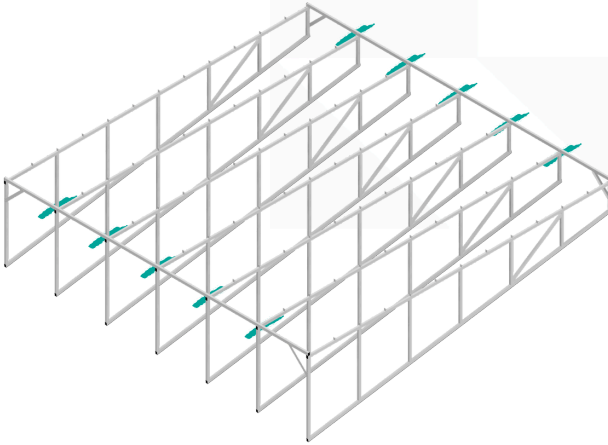

S3 Frame



20mm Tek Screws



8. Place the remaining **Frames** in position and fix to the **Cross Supports** using **20mm Tek Screws**.

9

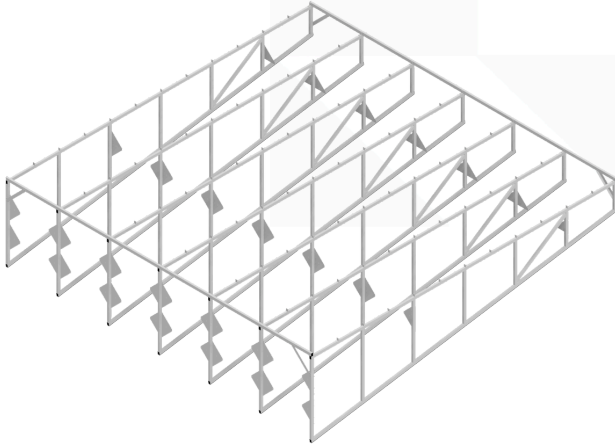

Square **Braces**



Half **Braces**



Quarter **Braces**



20mm **Tek Screws**

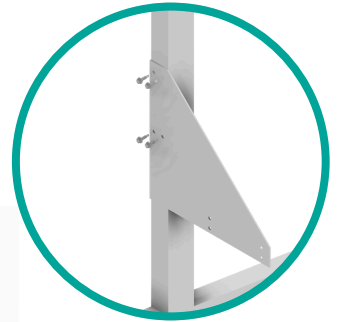
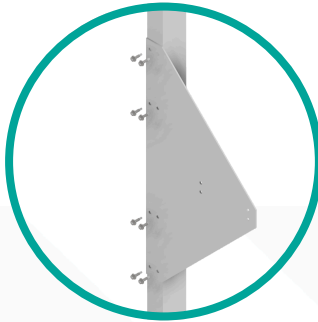
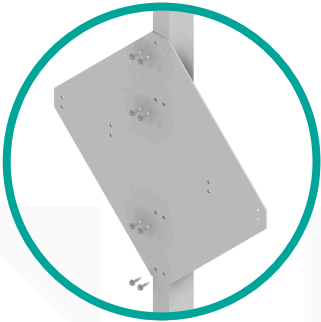

9. Fix the **Square Braces**, **Half Braces** and **Quarter Braces** to the **Frame** uprights using **20mm Tek Screws**, the locations for these will be shown on the **Plan Drawing**.

10

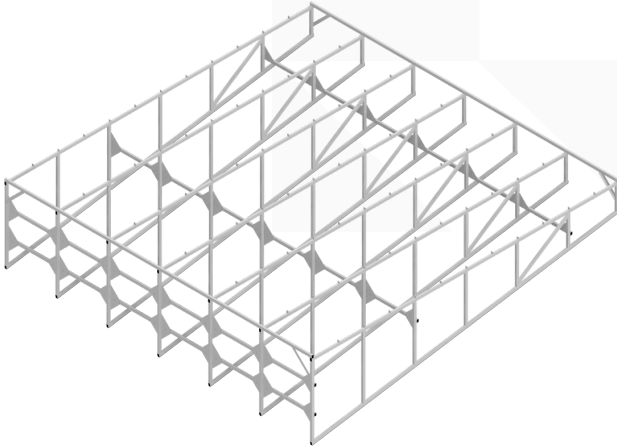

Cross **Support**



20mm **Tek Screws**

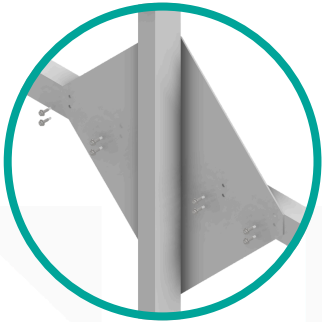

10. Slide in **Cross Supports** for each row of braces. Fix to each of the **Square, Half** and **Quarter Braces** with **20mm Tek Screws**.

11

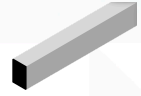
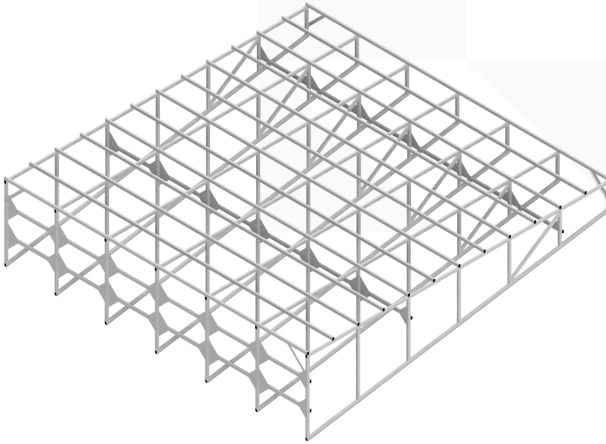

Cross **Support**



20mm **Tek Screws**

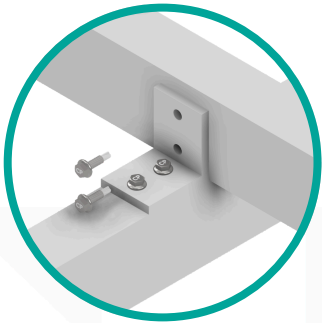

11. Place the rest of the **Cross Supports** in their positions on the **Frames** and fix to the **Frame** using **20mm Tek Screws**

12

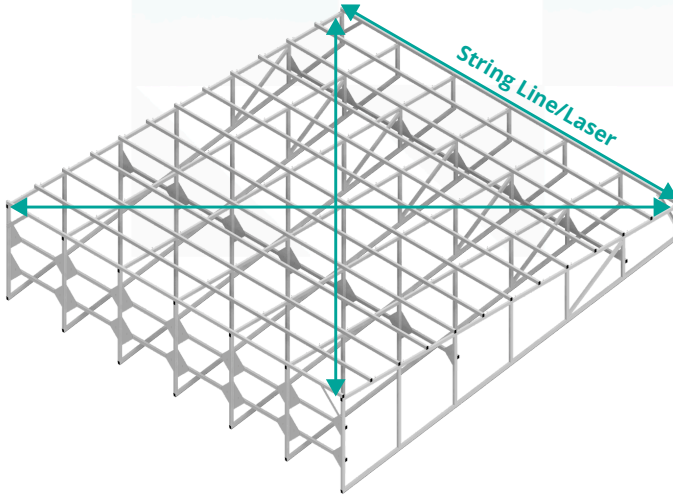

12. Ensure all fixings are in place and tight. Check for square using the platform's diagonal measurements and check that the frame is straight along the length by using a string line/laser.

13

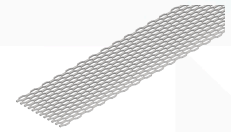
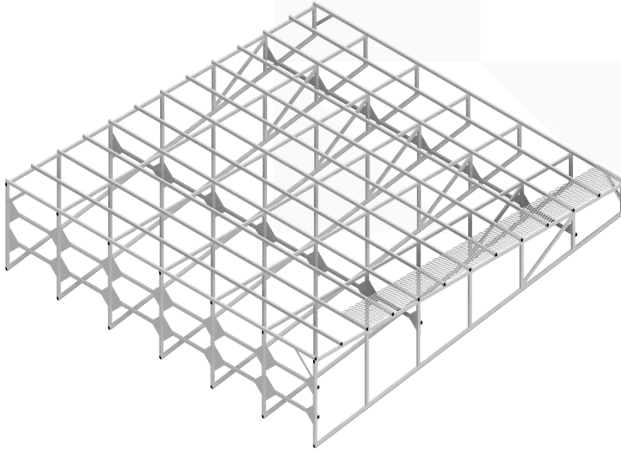

Mesh Sheet



35mm Tek Screw +
Hold Down Disc

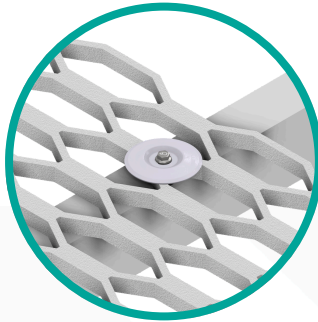
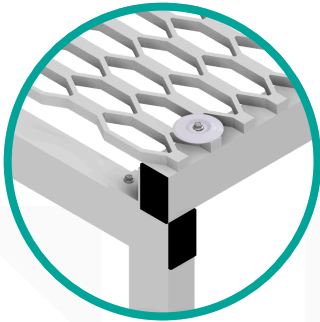

13. Place the **Mesh** on the **Cross Supports**, keeping it flush with the edges. Ensure the **Mesh** does not creep or run short when laid out, adjust placement before fixing. Fix **Mesh** ends using **35mm Tek Screw** with a **Hold Down Disc**, fixing to the **Cross Support** through the second full diamond of each **Mesh Sheet**.

14

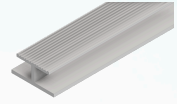
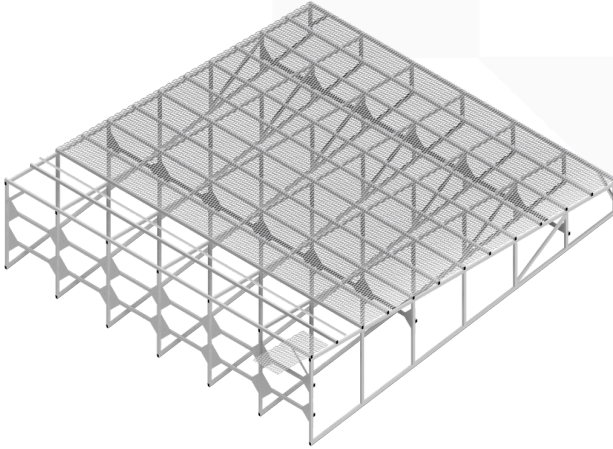

Mesh **Joiner**

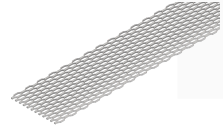

Mesh **Sheet**



35mm **Tek Screw** +
Hold Down **Disc**

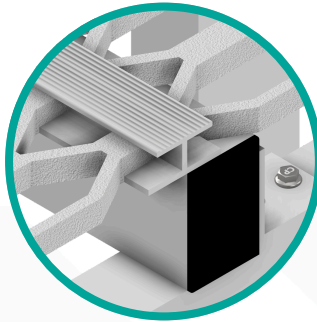
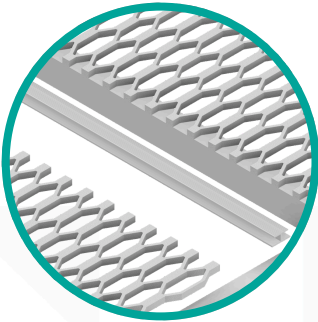

14. If additional rows of **Mesh** are required, fix the first row of **Mesh** down as **Step 13**. Place the end of each sheet of **Mesh** into the **Mesh Joiner** as you go, a rubber mallet can be used if required.

15

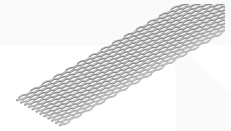
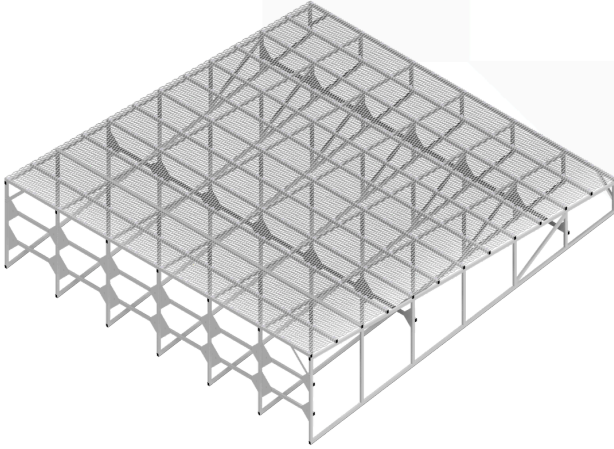

Mesh Sheet



**35mm Tek Screw
Hold Down Disc**

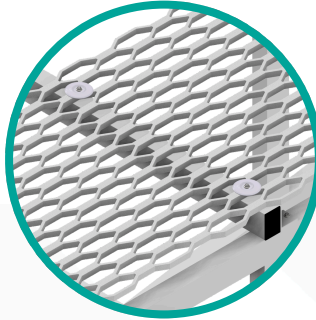
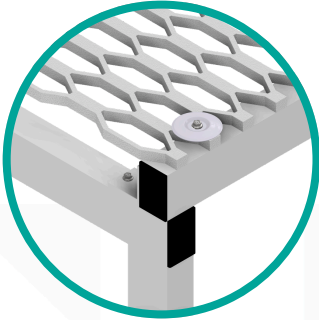

15. Fix the **Mesh** down in all the locations where the **Mesh** intersects each of the **Cross Supports**. Use **35mm Tek Screws** and **Hold Down Discs** in the second full diamond in from the edge of each **Mesh Sheet**.

16

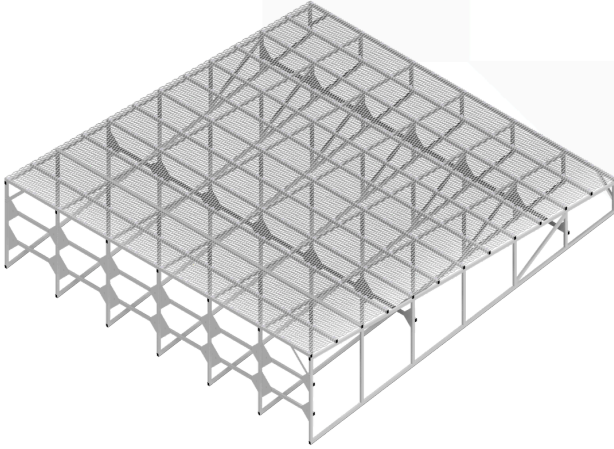

Certification Plate

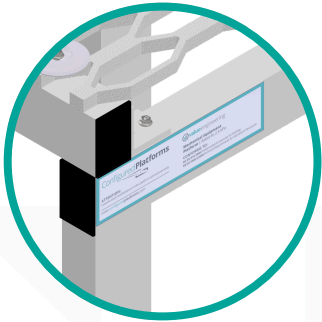

16. Fix the **Certification Plate** to one of the **Cross Supports** where it can be seen. Peel off the backing tape and pressing firmly on to the **Cross Support**.